

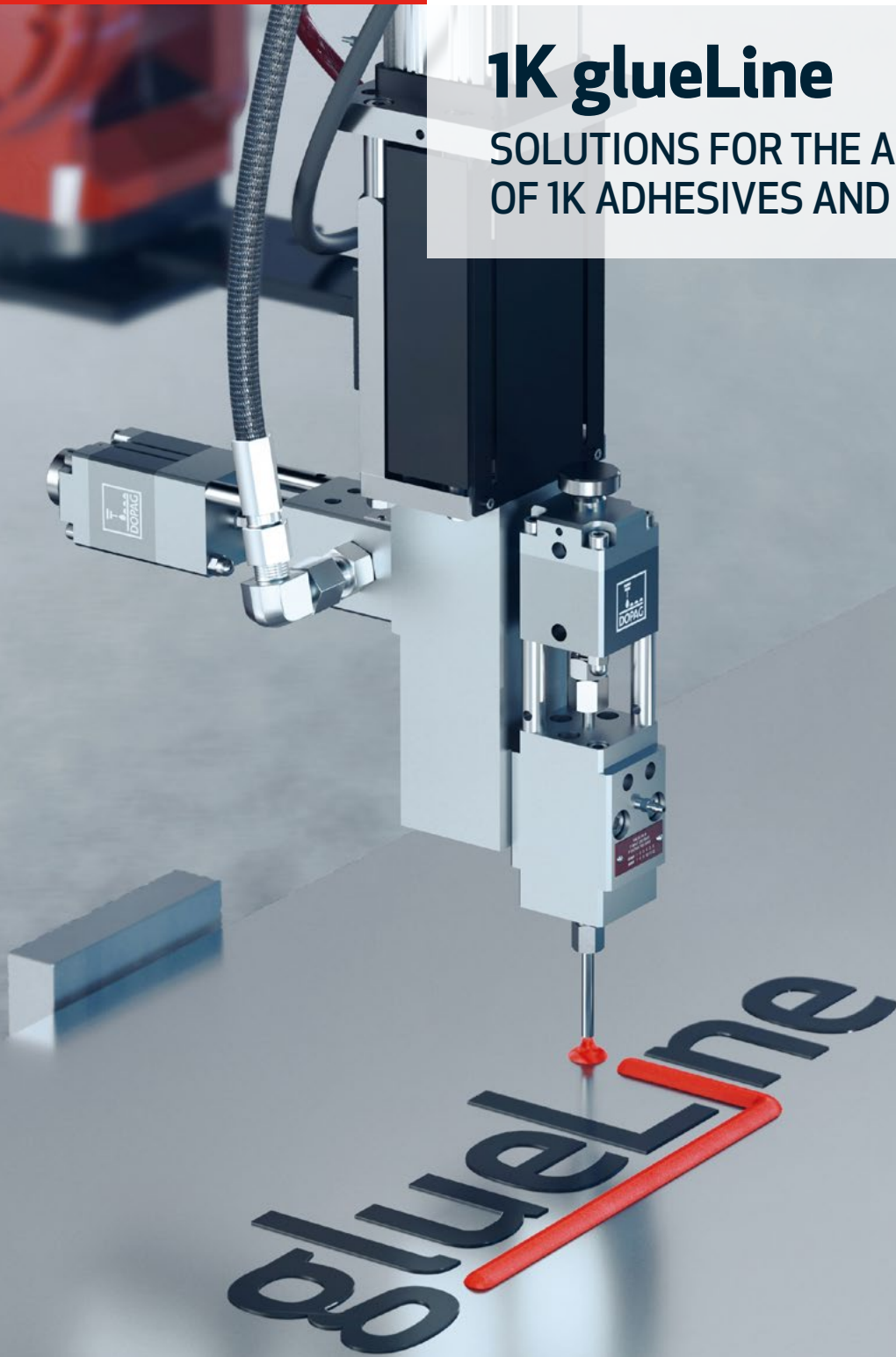

A MEMBER OF THE  
**HILGER&KERN** GROUP

# 1K glueLine

SOLUTIONS FOR THE APPLICATION  
OF 1K ADHESIVES AND SEALANTS



# Metering 1K materials

## Industrial application of adhesives and sealants



DOPAG single-component systems convey media such as adhesives, sealants, greases and oils with high precision from their original containers to the point of application, where the material is applied to the workpiece either in shot form or continuously in bead form. The systems are fitted with gear, piston or progressive cavity pump, depending on requirements.

Provided the medium is fluid or has low viscosity, single-component materials can be processed by means of a material pressure tank. For medium to high-viscosity media, drum pumps mounted on a double pump station are suitable for conveying the material. The application can be carried out manually or automatically. Metering technology from DOPAG is used numerous industries, including for household appliances, medicines and many more.

The joining technique of 'adhesive bonding' is well established in vehicle construction, rail vehicle construction, aviation and many other industries for several years. Thanks to newly developed adhesives, a wide variety of

materials can now be joined together in industrial production, including metals, plastics and glass. In many of these production processes, weight reductions are now possible in the finished products as a result, especially when joining fibre composite plastics with metal or with other material combinations.

By constantly optimising its plants, DOPAG has taken on a leading role in the market over the last few decades. In addition to precise processing, the adhesive is only applied to the substrate in the specified quantity. This enables an optimum result in terms of appearance and also ensures that no adhesive or sealant are wasted. All DOPAG systems operate in accordance with the new DIN 2304. This standard defines the professional implementation of bonding processes in operation and enables users to create a well-controlled process from the complex joining technique of 'adhesive bonding'.

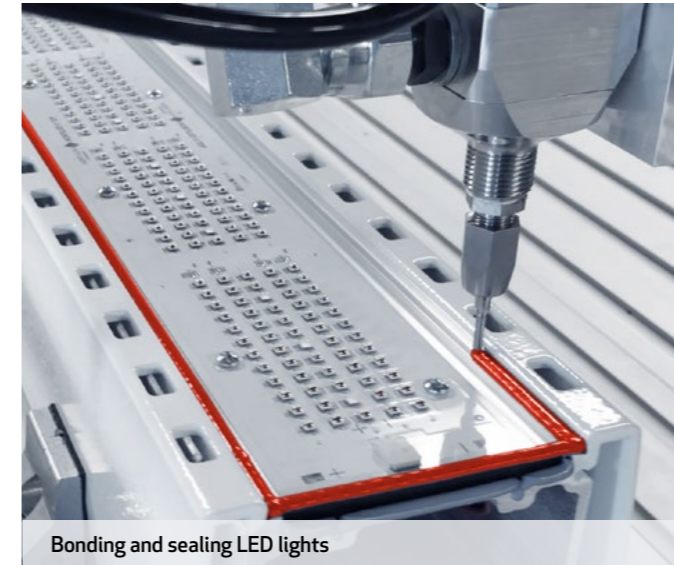

Bonding and sealing LED lights



Syringe filling with polyol and isocyanate



Bonding structural profiles for LKW trailers

## DOPAG always has the right solution

Whether it's individual components or a ready-to-use metering system, DOPAG offers an optimal and cost-efficient solution for every requirement. For example, our high-quality components, such as our pumps and valves, can be integrated individually into existing production lines or system concepts. This also includes our innovative metering pumps, such as our gear, piston and progressive cavity pump.

DOPAG also provides complete metering systems tailored to the specific requirements of your production processes. If the process requires it, we can provide additional automation units.

Project planning, coordination and construction of the systems are carried out in-house, always in close consultation with customers and partners. In our technical centre, we test system concepts as well as the latest technologies and materials on site.

# Products for the entire process

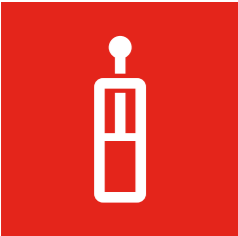

## Conveying & pumping ..... 06

- Piston pumps .....08
- Double drum pumps.....09
- Refill units.....10
- Pressure tanks.....11
- Material pressure regulators.....12



## Metering & application ..... 14

- Gear metering pumps .....16
- Piston metering systems.....18
- Progressive cavity pump.....20
- Needle metering valves .....22
- Diaphragm dispensing valves .....23
- Needle dispensing valves.....24



## Testing & controlling ..... 26

- Gear flow meters.....28
- Metering control unit .....29
- Stroke detection .....30
- Pressure sensors.....31



## Accessories ..... 32

- Additional components.....32

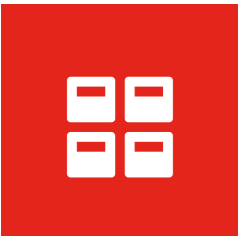

## System supplier ..... 34

- 1K gear metering system eldodis .....36
- 1K piston metering system vectodis .....38
- 1K eccentric screw metering system rotordis.....40
- Automated metering technology .....42



# Conveying and pumping

## Reliable processing of adhesives

.....



To ensure proper metering, it is important that adhesives are conveyed efficiently and without air any pockets (air bubbles). Only through continuous, reliable material supply can optimal metering results be ensured. Depending on the material properties, process and container size, different supply systems may be chosen. DOPAG's product range offers a comprehensive range of solutions for this. This includes drum and barrel pumps as well as pressure tanks. DOPAG uses established technology in all of its systems – gear, piston or progressive cavity pump. Thanks to the modular design, a conveyor system that is tailored precisely to the application and material used can be selected.

### Viscosity ranges of feeds

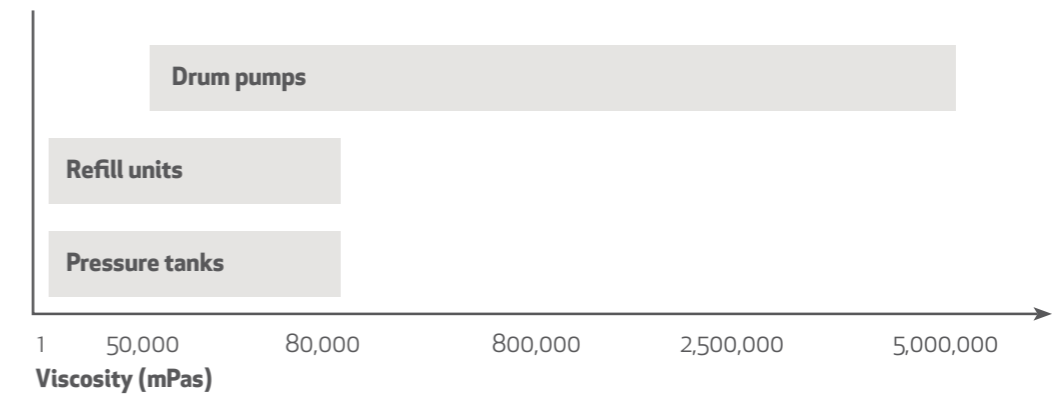

### Working ranges of drum and barrel pumps

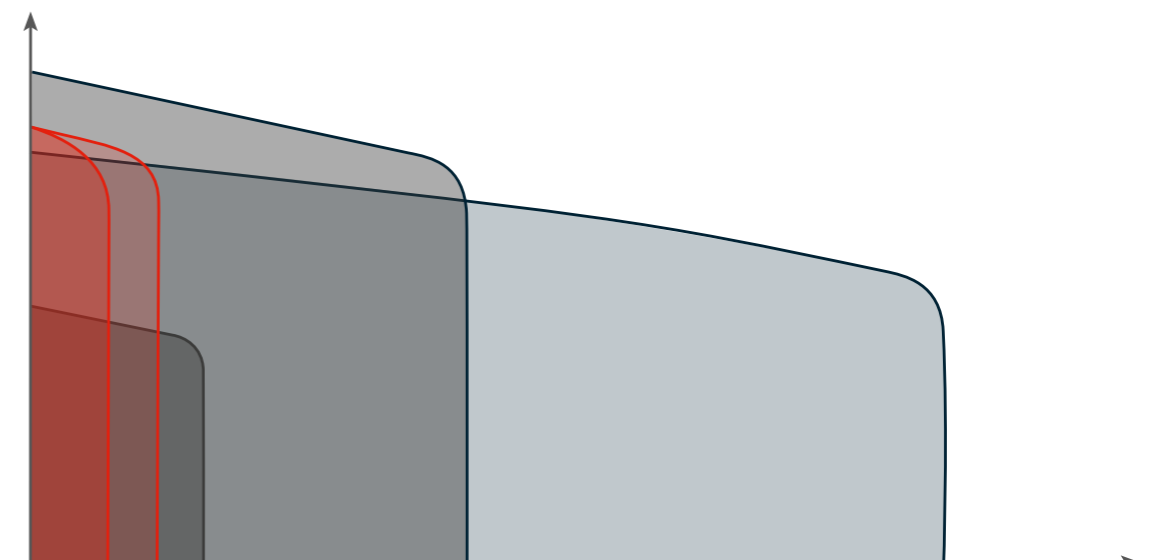

# Pumps for adhesives and sealants

## Efficient processing of single-component materials

DOPAG developed the drum pumps in the glueLine product range especially for feeding adhesives and sealants. The reliable design combined with the high level of user-friendliness allow for worry-free everyday production operations.

With the glueLine, DOPAG offers drum pumps for processing medium to high-viscosity materials. In addition to lubricants, they feed adhesives, sealants, polyurethanes and silicones with viscosities of up to 5.0 million mPas directly and precisely from the original container.

Thanks to its modular design and wide range of variants, the pump can be tailored precisely to the material used and customer requirements.

In addition to the standard design, versions in stainless steel, a wear-resistant version for abrasive fillers or with ATEX certification are also available. Different sealing options complete the broad portfolio.

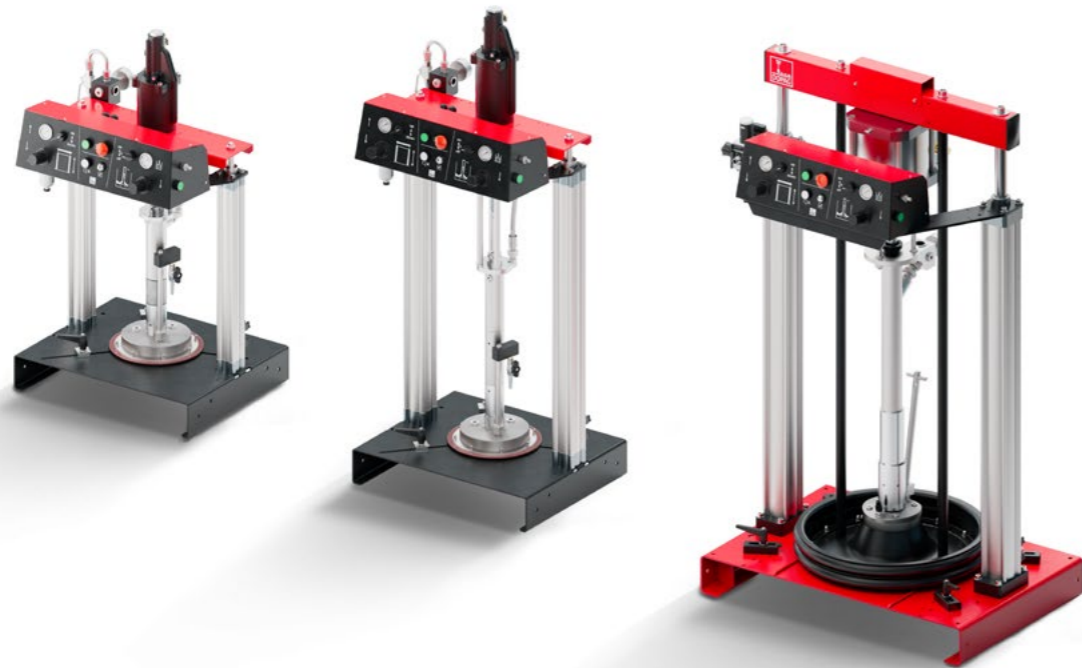

### Product features

- Sizes for 30, 80 and 200 litres
- For feeding medium to high viscosity materials
- Max. viscosity 5.0 million mPas
- Flow rate of up to 6 litres/minute
- Pressure ratio up to 75:1
- Double-acting piston pumps with fast-switching air motor
- 1- or 2-hand operation
- Modular design with various extensions and accessories
- Various seal types/materials available

## Double drum pumps

There are many applications where a continuous supply of material needs to be ensured at all times. For these cases, DOPAG also offers all drum and barrel pumps in tandem form. This features an automatic switchover between the pumps, so that the container can be changed

without interruption or time pressure. Clean handling as well as low residual quantities remaining in the barrel ensure efficient production design. From size P30 up, all pumps are available in tandem form.



## Refill units

To ensure uninterrupted production, automated refilling of the material pressure tanks is essential. DOPAG offers various compact refill units for this purpose. The fill level probe in the material pressure tanks enables refilling

to be started automatically from a defined material quantity. This ensures that there is always sufficient conditioned material available for production and machine downtime is avoided.



Depending on the material type, the following refill units are available:

- If the material needs to be stirred cyclically, this can be performed using an agitator and cyclic operation. Homogenisation during drum change is also possible.
- For more fluid systems, in particular, isocyanate, DOPAG offers refilling via a membrane pump.
- Silica gel air drying for use with media sensitive to atmospheric moisture
- Depending on material consumption, 200 L drums or 20/30 L containers can be selected. Refilling from 1,000 L containers is also possible. In the case of non-self-levelling materials, DOPAG offers a wide range of drum and barrel pumps.
- Dual refill units are optionally available for quick, convenient drum changes. Here, two material drums are positioned side by side on the collection tray, and the drums are replaced by swivelling the bell housing.

## Pressure tanks

Media with viscosities ranging from highly fluid to approx. 80,000 mPas can be conveyed directly from pressure vessels by means of compressed air and then applied. The tanks can be used within a system as intermediate storage or as the main feed. Depending on the requirements, different container sizes and various op-

tions are available for selection. Visual level indicators or electrical level probes provide information about the amount of material in the tank at any given time. Alternatively, the pressure tanks are also available with fittings provided.



### Product properties

- For low-viscosity media such as paints, oils and preservatives and all resins, including PU, epoxy and silicone
- Modular structure
- Operating pressure max. 6 bar (excess pressure)
- Vacuum-compatible
- Outlet below with ball valve
- Max. viscosity approx. 80,000 mPas
- Recirculation
- Silica gel air drying for use with media sensitive to atmospheric moisture

### Options

- Air maintenance unit
- Material filter on outlet
- Agitator
- Fill level sensor
- Heating sleeve
- Gauge glass
- Manual refilling via funnel

# Material pressure regulators

## Pulsation-free metering at optimum pressure

Material pressure regulators reduce the pressure of the material being conveyed down to the necessary working pressure. A material pressure regulator with a diaphragm is available for abrasive or reactive materials. Material pressure regulators of this type are ideally

used for the processing of reactive, moisture-sensitive, abrasive media (ball/seat design made from hard metal), such as epoxy resin, polyurethane and various other materials. The spring chamber is sealed by means of a diaphragm.



### Product properties

- Pressure reduction and smoothing of pulsations
- Standard sizes clear span 4, 8 and 12 mm
- Max. input pressure 250/400 bar
- Max. pressure reduction of 1:5
- Different output pressure (depending on version)

### Options

- Manometer
- Heating
- Replacement sieve in different mesh sizes
- Mounting bracket

### Technical specifications material pressure regulator with diaphragm

| Version *                        | LW4/50 bar | LW4/150 bar | LW8/50 bar | LW8/150 bar | LW12/50 bar | LW12/150 bar |
|----------------------------------|------------|-------------|------------|-------------|-------------|--------------|
| Clear span ø [mm]                | 4          |             | 8          |             | 12          |              |
| Flow rate at 50,000 mPas [l/min] | <0.5       | <1.0        | 0.5-12.0   | 1.0-24.0    | 3.0-24.0    | 6.0-24.0     |
| Input pressure max. [bar]        | 12-250     | 30-250      | 12-250     | 30-250      | 12-250      | 30-250       |
| Output pressure max. [bar]       | 4-50       | 10-150      | 4-50       | 10-150      | 4-50        | 10-150       |
| Connection input [G]             | 3/8"       |             |            | 1/2"        |             |              |
| Connection output [G]            | 4-50       | 10-150      | 4-50       | 10-150      | 4-50        | 10-150       |
| Dimensions (AxB) [mm]            | 55 x 55    |             |            | 65 x 65     |             |              |
| Height max. (C) [mm]             | 200        |             |            | 210         |             |              |

\* Other versions available on request

# Metering and application

## Maximum precision for your applications



Metering and dispensing valves from DOPAG meet all the criteria required for optimal metering results – high precision, excellent reproducibility and high quality standards. DOPAG offers different valve types with two operating principles. Needle metering valves meter volumetrically (dot application). In each metering cycle, the contents of the metering chamber are discharged, triggered by a signal. The benefits of this are high repeatability and flexibility thanks to adjustable volumes. In the case of dispensing valves, however, the metering volume is regulated via the material pressure and the opening time of the valve needle. This enables small amounts to be applied in bead form or any amount to be applied continuously. Depending on the application, a flow meter can also be used in combination with a gear metering pump.

Shot ranges of the metering techniques

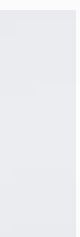
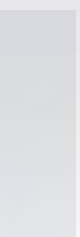
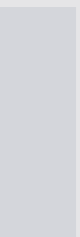
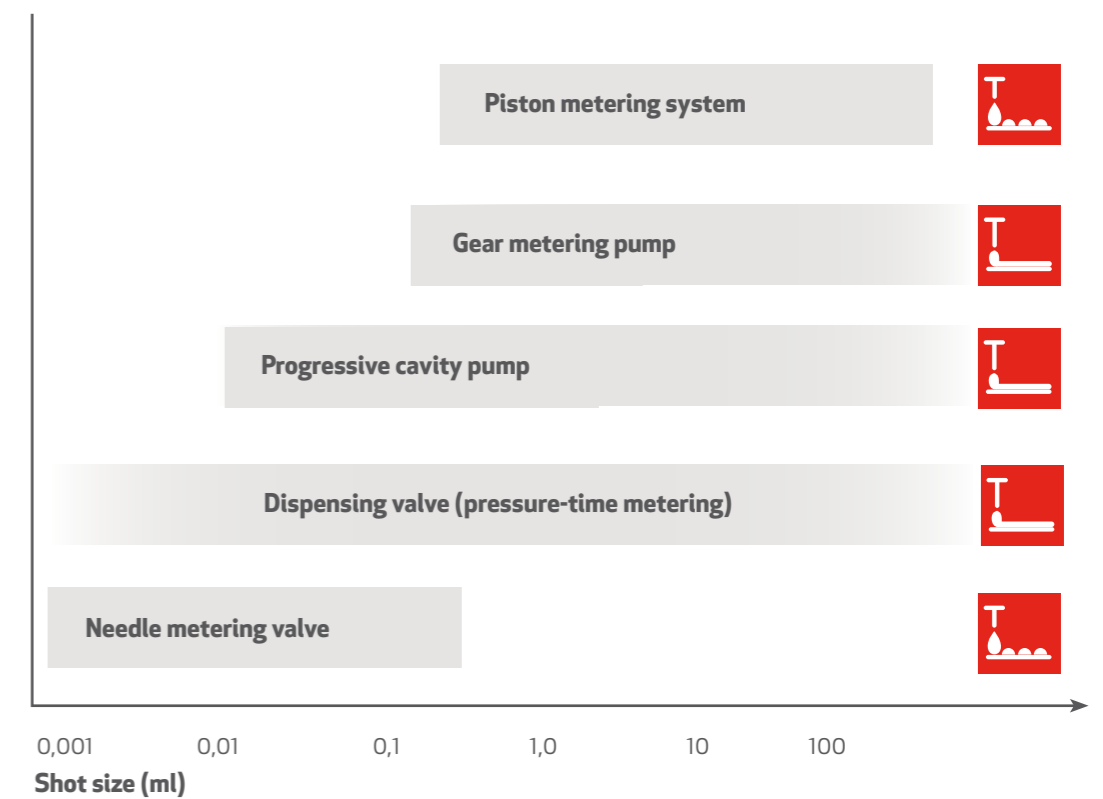

# Gear metering pump

## Metering materials continuously and precisely

Gear metering pumps from DOPAG offer all the features that are required in industry today. They meter a wide range of materials, including adhesives, sealants and lubricants, continuously and with consistently high precision. They are also designed in such a way that they are extremely robust, have a high level of efficiency and are practically pulsation-free.

Gear metering pumps are extremely versatile. Each version is available with different pump clearances, making them suitable for metering low to high-viscosity as well as pasty media. DOPAG gear metering pumps are suitable for use in general engineering as well as in other industries, such as aviation or wind energy.

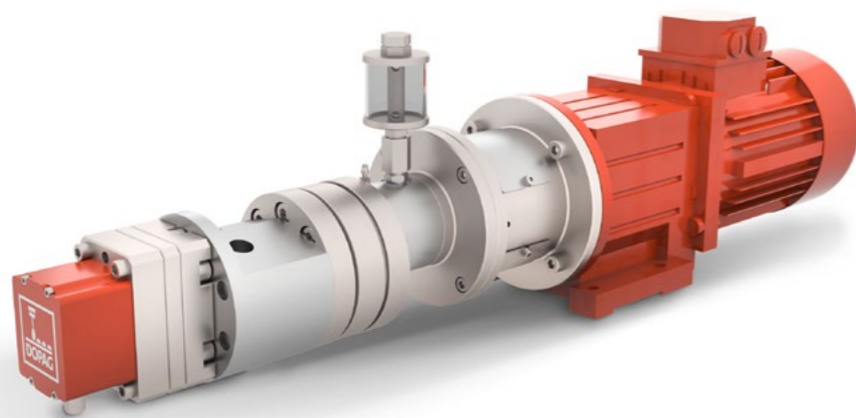

### Product properties

- Versatile use thanks to different pump sizes, clearance classes and seal systems.
- High-quality, hardened steel ensures operation even under difficult conditions.
- Special coating for protection against excessive wear and to ensure a longer service life
- Metering optionally available with gear flow meter
- Special versions available for special applications



### Seal systems

The gear metering pump can be fitted with one of four different seal systems. The seal systems have a modular design and can be replaced.

- 1. URF high-pressure seal:** This seal type ensures optimum fill level with highly viscous media by keeping the input pressure of the pump as high as possible.
- 2. VCR sealing sleeve:** This seal system is always used when the materials have a high proportion of fillers and when high chemical resistance is required.
- 3. RSS 3-fold shaft seal:** This seal type is used to good effect in a large number of applications. It can be used to cover a wide range of requirements.
- 4. MSE mechanical seal:** This seal is particularly suitable for highly filled materials, as it is extremely low-wear.

|                                  | URF | RSS    | VCR    | MSE         |
|----------------------------------|-----|--------|--------|-------------|
| <b>Abrasive media</b>            | 0   | -      | 0      | +           |
| <b>Max. input pressure [bar]</b> | 150 | 6      | 20     | 15          |
| <b>Temperature range [°C]</b>    |     | by 120 | by 120 | -20 to +120 |
| <b>Oil and grease resistance</b> | ++  | ++     | ++     | ++          |
| <b>Acid resistance</b>           | ++  | ++     | ++     | ++          |
| <b>Alkali resistance</b>         | ++  | ++     | ++     | ++          |
| <b>Wear resistance</b>           | +   | +      | +      | ++          |

### Pump sizes

The pump size and speed determine the conveying capacity. The pump size is indicated in ml per revolution.

#### Pump parameters

|                            |     |     |     |     |     |     |   |     |     |     |
|----------------------------|-----|-----|-----|-----|-----|-----|---|-----|-----|-----|
| <b>Flow volume [ml/U]</b>  | 0.1 | 0.3 | 0.6 | 1.2 | 1.8 | 2.4 | 3 | 4.8 | 6   | 10  |
| <b>Max. pressure [bar]</b> | 200 |     |     |     |     |     |   |     | 150 | 100 |

# Piston metering system

## Reliable metering with short cycle times

Piston metering units are used for processing 1K media, especially when short cycle times are required. All that is required is appropriate material supply and a metering calculator. The material is discharged in shot form at a freely configurable discharge rate or without interruption using a double piston system, e.g. in bead form. Different sizes are available depending on the requirements of the application. Combining two piston metering units together also enables 2K applications with this system.

It is powered by a servo motor, with a spindle converting the rotational motion into linear motion, thus ensuring precise piston feed.

Thanks to various design, there is practically no need for any maintenance work, which reduces service intervals and increases the durability of the products.



### Product properties

- Modular design enables a wide range of applications, variable mixing ratio and variable discharge quantity
- Maximum precision thanks to metering and mixing at point of application
- ± 1 % metering precision
- Multiple shots with one piston volume enable short cycle times
- High process reliability thanks to
  - Dead space design
  - Pressure monitoring in metering chamber
- Reduced maintenance work thanks to
  - Specially guided metering pistons
  - Compensating coupling between drive and metering piston
  - Hermetic sealing of piston with sealing medium

### Technical specifications

| Size                                      | ø3                 | ø6                 | ø10                | ø20                | ø36                |
|---|--------------------|--------------------|--------------------|--------------------|--------------------|
| <b>Max. metering volume</b>               | 0.45 ml            | 1.8 ml             | 7.8 ml             | 31 ml              | 101 ml             |
| <b>Min. metering volume (5 mm stroke)</b> | 0.04 ml            | 0.14 ml            | 0.4 ml             | 1.6 ml             | 5.1 ml             |
| <b>Metering stroke</b>                    | 65 mm              | 65 mm              | 100 mm             | 100 mm             | 100 mm             |
| <b>Max. output rate (Vmax)</b>            | 0.69 ml/s          | 2.75 ml/s          | 7.8 ml/s           | 31 ml/s            | 101 ml/s           |
| <b>Max. operating pressure</b>            | 160 bar            | 160 bar            | 160 bar            | 100 bar            | 100 bar            |
| <b>Viscosity range*</b>                   | 50-1,000,000 mPas  | 50-1,000,000 mPas  | 50-1,000,000 mPas  | 50-1,000,000 mPas  | 50-1,000,000 mPas  |
| <b>Max. dimensions</b>                    | 102 x 320 x 596 mm | 102 x 320 x 596 mm | 116 x 365 x 759 mm | 116 x 365 x 769 mm | 150 x 390 x 858 mm |
| <b>Weight</b>                             | Approx. 9 kg       | Approx. 9.3 kg     | Approx. 11.8 kg    | Approx. 14.9 kg    | Approx. 26.9 kg    |

\* Lower on request

# Progressive cavity pump

## Continuous metering of abrasive materials

The progressive cavity pump is a high-precision volumetric metering system that operates continuously and pulsation-free. The rotational motion of the eccentric screw ensures highly precise, constant metering, par-

ticularly in the case of small output rates from 0.1 ml/min. The special rotor-stator combination prevents excessive wear when processing abrasive materials. This guarantees a long service life and high cost-efficiency.

Thanks to progressive cavity pump technology, liquids and pastes with up to 60% filler content can be metered with high precision. The metering quantity can be adjust-

ed completely linearly. This enables a metering precision of  $\pm 1\%$  and better.



### Product properties

- Variable discharge rate from 0.002 ml
- Output rate of 0.1 to 4,400 ml/min
- Speed of 1 to 150/400 rpm (depending on model and medium)
- Maximum input pressure of 6 to 8 bar
- Maximum differential pressure of 10 to 20 bar
- Ideally suitable for all viscosities from highly fluid to pasty

### Options

- Cartridge supply 10cc / 30cc / 55cc
- Pressure regulator and level control for cartridge supply
- Spray adaptor
- Servo controller
- Various needle tips

### Sizes

| Size | Flow volume<br>ml/rev     | Input pressure<br>bar | Operating pressure *<br>bar | Speed range * min. <sup>-1</sup><br>min. / max. |
|------|---------------------------|-----------------------|-----------------------------|---|
| 1    | 0.01 / 0.05 / 0.15 / 0.30 | max. 6                | max. 10                     | 1 / 150   |
| 2    | 0.30 / 1.00 / 2.00        | max. 8                | max. 20                     | 1 / 400   |
| 3    | 4.00                      | max. 8                | max. 20                     | 1 / 400   |

\* Depending on viscosity

## Needle metering valves

### Greater accuracy for small dot size

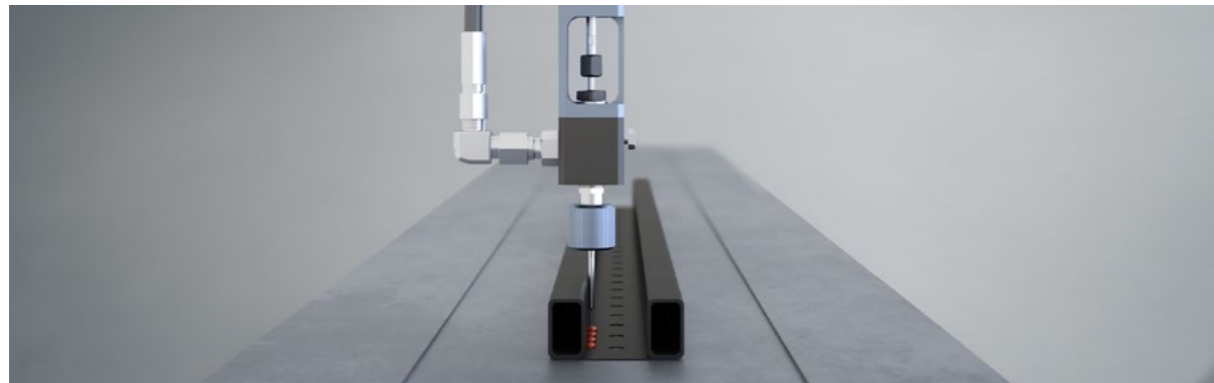

The needle metering valve works according to the volumetric metering principle, application is carried out in shots. The metering quantity is fixed by means of a stop screw. This ensures extremely high repeatability, reproducibility and process reliability at all times. The same valve can be used for different metering quantities and end products.

The needle metering valve is insensitive to pressure fluctuations (3–50 bar) and thus also independent of viscosity and temperature changes. A system temperature control device is not necessary. Pressure tanks can be used to process low-viscosity materials. The material is ejected directly from the needle metering valve. This is why extremely short cycle times are possible.

With the DOPAG Long Life Seal concept, up to 10 million shots are possible leak-free. Compared to existing variants, this results in 20 per cent lower maintenance costs and fewer interruptions to your production process.

#### Product features

- Dot application (volumetric dispensing)
- Shot size 0.001 – 3.00 ml (depending on model)
- Material input pressure 3 – 50 bar
- Compatible with stroke detection (see p. 29)
- Sealing available in various sizes and material finishes

The needle metering valve features a pneumatic drive. This is separated from the metering chamber. The material cannot penetrate the drive cylinder and interfere with the movement of the valve needle. That is why the valve also processes reactive, aggressive and abrasive adhesives.

The magnetic stroke sensor installed in the valve makes it possible to use common C-slot sensors. They work magnetically, are more accurate, and are quick and easy to install. The process reliability is increased, as is the position query accuracy.

#### Benefits for you

- Unique minimal quantity valve with a minimum metering volume of 0.001 ml
- Up to 10 million shots leak-free thanks to the DOPAG Long Life Seal concept
- Metering accuracy < ±1 per cent
- Short cycle times with up to 2 shots per second

#### Options

- Solenoid valve plate 24 V
- Signal generator with various cables
- Various adapters and needle tips
- Micro-flow sensor (see p. 28)
- Pneumatic or electric handle
- Spray adaptor

## Diaphragm dispensing valves

### Clever solutions to the greatest challenges

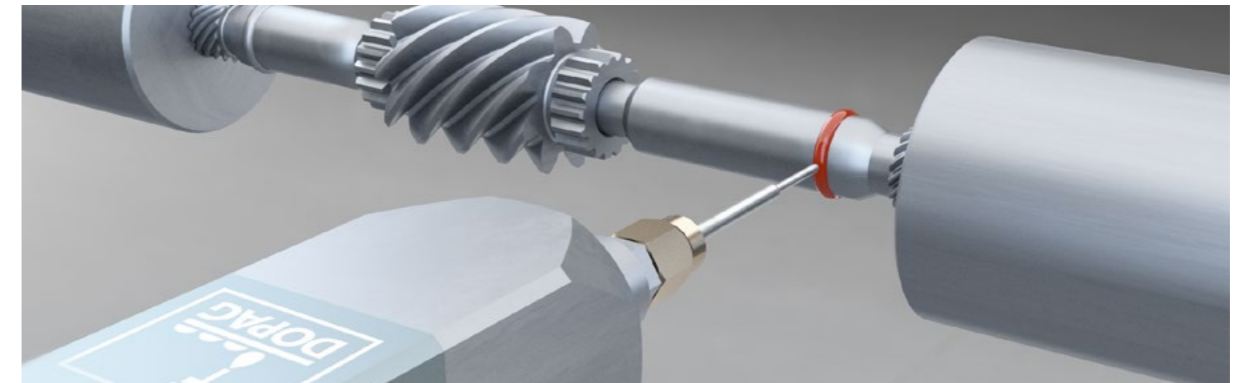

This series features a unique high-pressure membrane design. The drive and metering element are hermetically sealed via a high-pressure membrane and the parts that come into contact with the material are made of stainless steel. On the one hand, this enables the processing of highly reactive materials. At the same time, it is ensured that there is no abrasion due to fillers on the drive and sealing system. In addition, the closing elements are made of carbide, which ensures extremely high wear resistance.

The diaphragm dispensing valve is available in different sizes. We can configure the optimum variant for each material and different discharge quantities or viscosities. The snuff-back effect prevents dripping and ensures a clean and accurate thread break.

#### Product features

- Continuous application (time-pressure dispensing)
- Internal diameter 2, 4 and 8 mm
- Max. input pressure 160 bar
- Snuff-back effect

An additional adjustment option is offered by the stroke adjustment. If necessary, fine-tune the amount of material directly on the valve, the pressure remains the same and you work with the best possible configuration.

#### Benefits for you

- Unique worldwide: Leak-free at high pressure level (maximum pressure up to 200 bar)
- Reliable application of abrasive, reactive and aggressive materials
- Maximum wear resistance for long service lives
- Clean break, absolutely uniform material application

#### Options

- Solenoid valve plate 24 V
- Various adapters and needle tips
- Pneumatic or electric handle
- Heated valve with or without plug 230 V AC / 200W

# Dispensing valves

## High flexibility with continuous discharge

Dispensing valves are suitable for the continuous discharge of low to high-viscosity materials based on the pressure-time metering principle. The dispensing valve consists of two structurally distinct parts. The advantage of this is that the material cannot penetrate the drive cylinder and impair the movement of the valve needle-

dle. The size of the opening cross-section is regulated by means of the stroke adjustment. The valve needle is sealed against the valve head space by means of an adjustable special seal. This ensures clean, precise metering at all times.

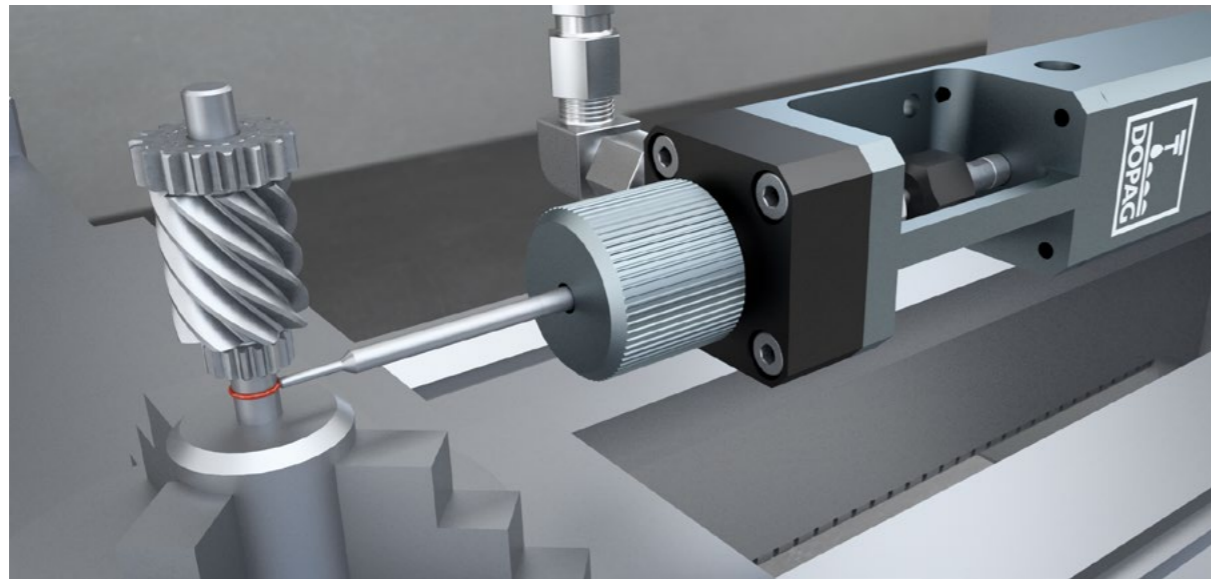

### Product properties

- Continuous applications (pressure-time metering)
- Clear span (LW) 1, 2.5, 6, 8, 12 and 16 mm
- Material input pressure max. 250 bar
- Prepared for stroke detection
- Various types of seals/materials available

### Options

- Solenoid valve plate 24 V
- Transducer with various cables
- Cannula connection with various cannulas
- Handle pneumatic/electrical



# Testing and controlling

## Reliable and reproducible metering

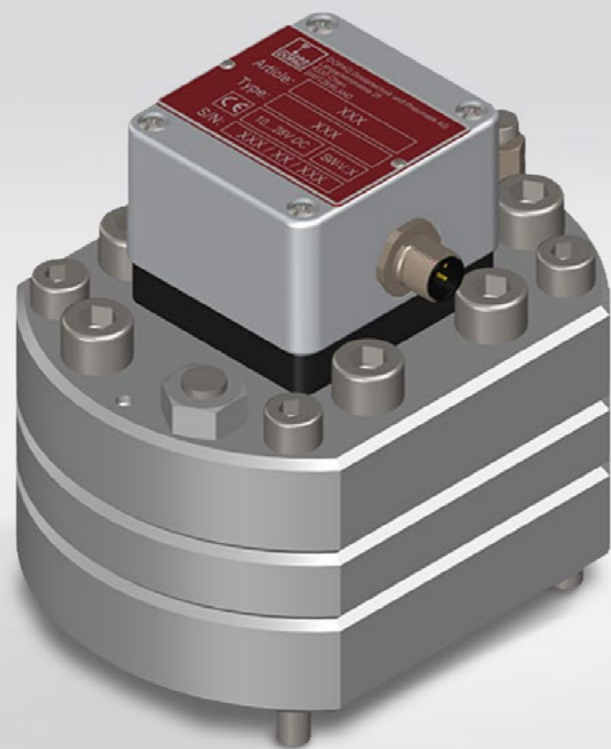

Metering processes are shaped by short cycles, high repetition rates and tightly defined tolerances. In addition, often only very small amounts are applied. It is therefore even more vital that the metering is reliable, precise and reproducible. The process capability and the repeatability of an application must be controlled and documented in modern production processes. These requirements should be precisely defined and taken into account when producing the system concept. DOPAG offers a comprehensive range of testing and control technology, including, gear flow meters, light barriers, pressure sensors and metering control units. In the system design, DOPAG coordinates process control and monitoring with the customer in line with the particular application and combines this with the appropriate pumps and metering components.

### Pressure/time flow chart and volumetric metering

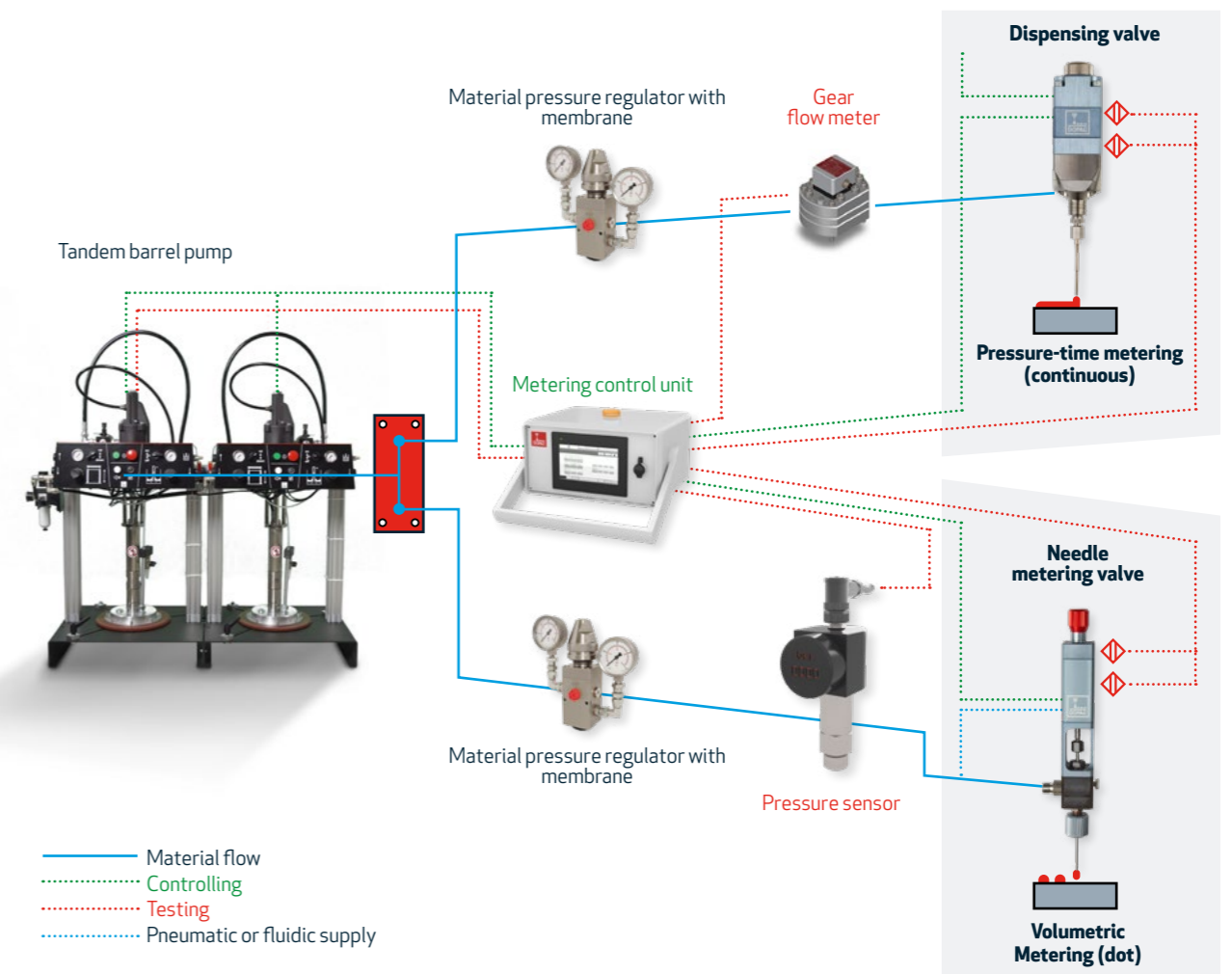

## Gear flow meter

### Precise monitoring of metering

DOPAG has developed the gear flow meter specially for use in its own metering and mixing systems. In the processing of single-component media such as greases and oils, it precisely measures the flow rate during the metering process. The measuring principle is based on the volumetric gear displacement system, which offers high precision and pressure resistance. The measuring

unit is based on a pair of precisely fitted gears placed in the housing of the flow meter. The rotation of the measuring unit is detected gear by gear by a non-contact signal transducer system and converted into digital pulses. The metering unit, a gear flow meter combined with a flow-regulating and dispensing valve, is used to ensure precise discharge or filling of larger quantities.



#### Product properties

- Monitoring, regulating and controlling metering
- Material-guided components made from stainless steel
- With pulse multiplication
- Gear volume 0.04 / 0.2 / 0.4 / 2 cm<sup>3</sup>
- Available in ball bearing or plain bearing variants

#### Options

- Sensors
- Various connection and adapter plates
- Heated connection plates
- Connection cable

## Metering control unit

### Linking and controlling metering components

The MR40 metering control unit was specially designed by DOPAG to manage complex metering processes. It can be integrated easily into systems with a metering valve as well as into 1K metering units with a dispensing valve. The control unit enables communication between the individual system components and coordinates the various features of the metering components. In addition, the software enables various metering programmes

to be stored, which can be accessed as required and according to the application. The metering control unit features interfaces for connection to various material feeds and is compatible with measuring devices such as gear flow meters and other accessories. It can be used either as a system control unit or as an interface between a higher-level system control units and the metering system.



#### Product properties

- Power supply 230 VAC 50 / 60 Hz
- 7" touch panel for operation
- USB port for program updates
- Indicator lamp with buzzer in case of error messages

#### Options

- Profibus, Profinet or Ethernet IP module
- Various connection and heating cables
- Display protective film

#### Types

- Desktop housing: plastic, 370 x 330 x 200 mm, with clamps
- Wall housing: tin, 400 x 400 x 210 mm, with mounting brackets

## Stroke detection

Reliable monitoring of metering process

With stroke detection, the metering process can be monitored for various valve types. Here, the stroke movement of the metering needle or metering piston is detected. This signal serves as an indicator for optimum valve functionality and improves process reliability in automated applications.



Suitable with:

- Needle metering valves
- Dispensing valves

## Pressure sensors

Controlling shot valves

Pressure sensors are used either securely mounted on shot valves or positioned upstream within the system. They display the respective material pressure or transmit this to a measuring unit. In the case of vectodis and the 1K gear system, they are used for process monitoring.



Suitable with:

- Integration in system (digital/analogue)

# Accessories

## Additional components

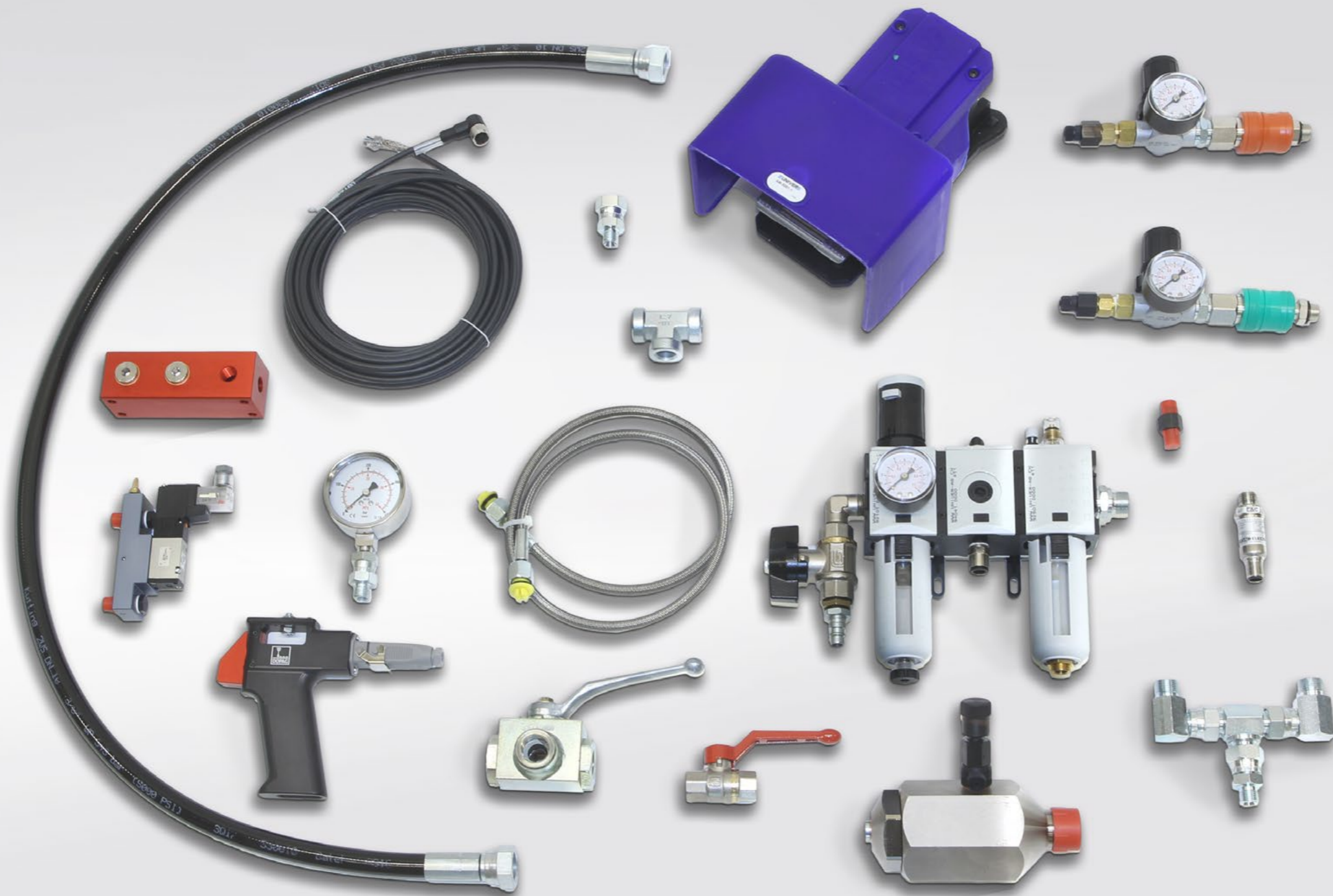

The comprehensive range of accessories combines the metering components and pumps in a single complete system. Our technicians would be happy to help you choose the right components:

- Distributor blocks
- Heating hoses
- Pneumatic hoses
- Material hoses
- Manometer
- Material filter
- Mixing tubes
- Check valves
- Adapters
- Heating



# System supplier

## All in one



High-quality components from DOPAG are available individually and can also be put together in the form of a complete system solution.

The required pump technology, metering system and discharge unit are selected according to the specific application.

The system can also be integrated into an automation unit.

# eldodis

## 1K gear metering system

DOPAG developed the eldodis gear metering system specially for the processing of medium to high-viscosity single-component materials. The material is input via a feed pump, a material pressure tank or by means of a cartridge-extracting device. A material pressure regulator ensures constant input pressure. A shut-off valve can optionally be installed in front of this to provide additional protection for the gear metering pump. The metering pump, powered by a gear motor, conveys the material to a dispensing valve where continuous material discharge takes place via a nozzle or cannula.

The conveying capacity of the system is largely determined by the size of the gear metering pump and the pump speed. The latter can be controlled by means of a frequency converter built into the control unit. A volume counter can be installed downstream of the gear metering pump to check or also control the metered quantity in a closed loop and to increase process reliability. All components are connected to a metering control unit. This also enables integration into partially or fully automated production or assembly processes through all standard interfaces.

1. Drum pump
2. Piston metering pump
3. Dispensing valve
4. Metering control unit



### Product properties

- The gear metering pump can be fitted with one of four different seal systems.
- Coated variants against wear and for poorly lubricating media
- Different versions for different viscosities and fillers
- ± 1 % metering precision

### Technical specifications

|                              |   |
|------------------------------|---|
| <b>Material discharge</b>    | From 1 ml/min, depending on viscosity   |
| <b>Operating pressure</b>    | Up to 200 bar, depending on material and discharge rate   |
| <b>Material supply</b>       | Material pressure tanks 4, 12, 24, 45, 60 or 90 L, larger available on request<br>And/or barrel pumps |
| <b>Viscosity range</b>       | 50 to 80,000 mPas, with material pressure tank<br>Max. 150,000 mPas, with barrel pumps*               |
| <b>Material properties</b>   | Unfilled, filled, abrasive  |
| <b>Operating voltage</b>     | 400/230 VAC 3/N/PE / 50/60 Hz   |
| <b>Compressed air supply</b> | 6 bar max.  |
| <b>Dimensions, W x H x D</b> | Modular structure, so no specific machine dimensions  |
| <b>Weight</b>                | Modular structure, so no specific machine weight  |

\* Higher available on request, depending on rheological properties of material

# vectodis

## 1K piston metering system

The vectodis metering system is suitable for processing single-component media. The material is discharged in shot or bead form. The material is taken from the original container via a feed pump and fed to a piston metering unit with a servo motor. A material pressure regulator keeps the input pressure at the piston metering unit constant. The material is discharged via a dispensing valve located at the outlet of the piston metering unit. The metering control unit enables communication between

the individual system components and coordinates the various features of the metering components. It can be operated conveniently via a touch panel. All the relevant process data is displayed here. The metering control unit enables features such as speed-proportional metering, which allows vectodis to be combined with an industrial robot. The software also provides modern features such as pre-compression and leakage control for reliable, reproducible application over the long term.

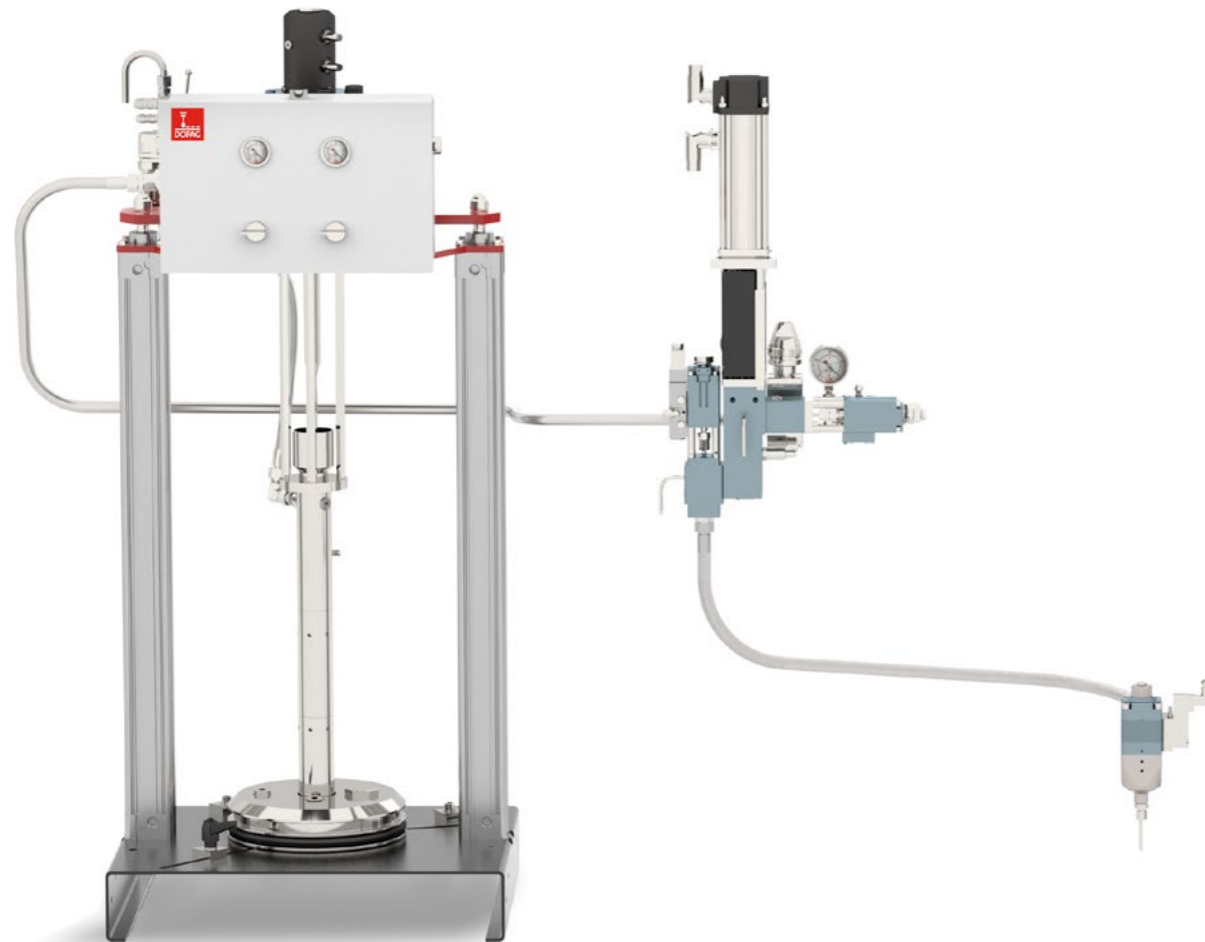

1. Drum pump
2. Gear metering pump
3. Dispensing valve
4. Metering control unit

# rotordis

## 1K eccentric screw metering system

rotordis is an progressive cavity metering system designed for conveying and metering single-component materials. It is suitable for water-thin to paste-like, highly viscous media. The medium can be supplied from pressure tanks or drum pumps, depending on the viscosity. A material pressure regulator ensures constant input pressure. It is generally applied directly from the metering system onto the component. Together with the servo-motor drive, this enables both dynamic metering and a controllable back suction effect for a clean thread break. In the case of limiting ambient conditions, a hose connection and dispensing valve can also be used.

The heart of the system, which consists of only two components, is the stator-rotor combination. This is a volumetric metering system that is sealed leak-free. It conveys the material continuously through the system without volume limitation, with low shear and gently in the axial direction, making it particularly suitable for filled media.

The electronic metering control unit, which is specially customised for this metering system, ensures optimal customisation of all application-specific parameters and supports integration into automated production processes through a standardised interface. The integrated touch panel ensures simple, clear communication with the operator.



3

### Product properties

- Uninterrupted metering
- Speed-proportional conveying
- Valve-less system
- Conveying of abrasive media
- Low pulsation and shear
- High repeatability and metering precision,  $\pm 1\%$

1. Material pressure tank
2. Progressive cavity pump
3. Metering control unit



## Technical specifications

| Series  | 1           | 2           | 3           | 4          |
|---|-------------|-------------|-------------|------------|
| Nominal size [ml]                                 | 0.01        | 0.05        | 0.15        | 0.30       |
| Metering quantity [ml/rev]                        | 0.013       | 0.059       | 0.163       | 0.3        |
| Flow rate [ml/min]*                               | 0.13 – 1.95 | 0.59 – 8.85 | 1.63 – 24.5 | 3.0 – 45.0 |
| Min. metering volume [ml]**                       | 2 x 0.002   | 2 x 0.008   | 2 x 0.01    | 2 x 0.03   |
| Speed range (min ... max***) [min <sup>-1</sup> ] | 10 ... 150  | 10 ... 150  | 10 ... 150  | 10 ... 150 |
| Pwork (Inlet pressure) [bar]                      | 0 – 6       |             |             |            |
| Pmax (Max. pressure) [bar]                        | 10          |             |             |            |
| Metering accuracy                                 | $\pm 1\%$   |             |             |            |

\* At speed range 10–150 rev/min

\*\* Depending on material properties, nozzle size, alignment of PCP etc.

\*\*\* Depending on viscosity

# Automation for 1K metering applications

For automated metering, DOPAG offers production cells that can be customised modularly to different applications. In addition to standard cells without component feed, individual production cells are provided based on the specific requirements. This means that several production steps can be fully automated, such as plasma pre-treatment during the joining process.

DOPAG offers a complete inline solution for fully automated implementation of several work steps in sequence. For example, the plasma pre-treatment and adhesive bonding and sealing steps, as well as the joining processes, can be performed in three interconnected cells.

## Technical specifications

|  | Cell type 1   | Cell type 2            | Cell type 3        |
|--|---|------------------------|--------------------|
| <b>Size (W x D x H), mm</b>                | 1200 x 1200 x 2400  | 1600 x 1500 x 2400     | 1800 x 1700 x 2400 |
| <b>Load carrier dimensions (W x D), mm</b> | 800 x 500   | 1000 x 700             | 1200 x 900         |
| <b>Robot type</b>                          | FANUC LR Mate 200iD   | FANUC LR Mate 200iD/7L | FANUC M10iD/12     |
| <b>Control panel</b>                       | Self-explanatory operator guidance for configuring and controlling the machine<br>10,1" handheld operating box,<br>18" optional control panel |                        |                    |

## Options and accessories

- Modular design, individual customisation
- Simple workpiece carrier pick-up, manually or pneumatically operated
- Double (tandem) workpiece carrier pick-up, manually or pneumatically operated
- Safety door, pneumatically operated
- Access protection through light curtains, scanners, step mats
- Barcode reader for individual, automated selection of machining programme
- Connections for extraction systems
- Camera systems for identification and location checking of components



Production cell



Line integration-capable production cells



**A MEMBER OF THE  
HILGER&KERN GROUP**

We are one of the world's most experienced manufacturers of high-quality metering technology. Wherever adhesives, resins, silicones or lubricants are metered and applied in industrial production, we offer reliable, precise solutions. We provide systems and components for highly automated production processes, including for the automotive, wind, household appliances and electrical industries, as well as for aviation.

DOPAG is part of the HILGER & KERN GROUP, a reliable supplier and a development and service partner to industrial companies in a variety of market segments for almost 100 years. The group employs around 350 people and has subsidiaries and distributors in more than 40 countries.



## Global sales and service network

Find your local DOPAG contact



### **DOPAG Benelux**

De Meern

info@dopag.nl  
www.dopag.nl

### **DOPAG China**

Shanghai

office@dopag.cn  
www.dopag.cn

### **DOPAG Eastern Europe**

Dolní Rychnov

info@dopagcz.com  
www.dopagcz.com

### **DOPAG France**

Valence

contact@dopag.fr  
www.dopag.fr

### **DOPAG Germany**

Hilger u. Kern, Mannheim

info@dopag.de  
www.dopag.de

### **DOPAG India**

Bangalore

sales@dopag.in  
www.dopag.in

### **DOPAG Italy**

Alpignano (Torino)

info@dopag.it  
www.dopag.it

### **DOPAG Korea**

Seoul

info@dopag.co.kr  
www.dopag.co.kr

### **DOPAG Mexico**

Saltillo, Coahuila

sales@dopag.mx  
www.dopag.mx

### **DOPAG Nordic**

Gothenburg

info@dopag-nordic.com  
www.dopag-nordic.com

### **DOPAG Switzerland**

Cham

info@dopag.ch  
www.dopag.ch

### **DOPAG UK**

Droitwich

uksales@dopag.com  
www.dopag.co.uk

### **DOPAG USA**

Erlanger, Kentucky

ussales@dopag.com  
www.dopag.us

We're present in more than 40 countries. Find your local sales partner here:  
[www.dopag.com/contacts](http://www.dopag.com/contacts)

